



S I S T E M A
COLOSAL PC 2.6
PUERTA CORREDIZA



COLOSAL[®]

2.6 PUERTA CORREDIZA

3 | DESCRIPCIÓN

RESULTADO: TEST AEV 21-004 | 4

5 | RESULTADO: TEST AEV 21-005

TIPOLOGÍA XO ANJEO | 6

7 | TIPOLOGÍAS

REFERENCIAS BÁSICAS | 8

9 | REFERENCIAS OPCIONALES

REFERENCIAS PC SATELITAL 2.6 | 10

PRESIONES, RESISTENCIAS Y TAMAÑOS | 11

TABLA DE RESTRICCIONES

TR-01	TR-04
TR-02	TR-05
TR-03	

17 | TABLA DE DESCUENTOS OX - XO

TABLA DE DESCUENTOS SATELITAL | 18

19 | ACCESORIOS

APLICACIÓN DE EMPAQUES | 20

21 | MAQUINARIA Y EQUIPOS



PUERTA CORREDIZA

- Puerta Corrediza Colosal 2.6, que cuenta con elegante diseño de un cuerpo fijo y una nave móvil, con máxima estanqueidad y seguridad, gracias al diseño de sus perfiles y localización de las felpas. La nave se desplaza en forma silenciosa y sin movimientos laterales, sobre un riel angulado que amplía la superficie de contacto con el rodamiento, montado sobre balineras o agujas para garantizar las cargas y ciclos de operación.
- Tipologías posibles: OX, XO, XX, XOX 1/3, XOX 1/4, OXXO, XXX, XXO, OXX, X
- Altura máxima recomendada de 2.70 metros (consultar tablas de restricciones).
- Garantizada para ciclos de operación de rodamientos según peso de la nave. (ver tabla pág. 16)
- Posibilidad de usar cristales con espesores desde 5, 6, 8, 10 mm. con empaques diseñados para los mismos.
- Sellamientos dobles con felpas entre el marco, la nave, entrecierres y los rieles superior e inferior de la puerta para lograr mayor hermeticidad y una óptima protección a filtraciones de polvo en su interior.
- Las naves se encuentran encajadas en el riel superior del marco para mejorar su fucionabilidad, estructura e insonorización.
- Riel Inferior del marco con pendiente de 5 grados para facilitar la evacuación de líquidos: estanqueidad.
- Los diseños de los perfiles horizontales y verticales del marco tienen pestañas que permiten ensamblar otras pistas, rieles y marcos, que sirven para añadir otras naves o cuerpos de anjeos corredizos sobre el diseño básico.
- El concepto Colosal acepta un sistema satelital 2.6 para diseños de una sola nave corrediza, sin cuerpo fijo, dentro de un muro hueco o en la parte posterior a una pared.

RESULTADO: TEST AEV 21-004

MAYO 24: 2020 – FAPIM, ITALIA

MEDIDAS: (axh) 2.000 x 2.400 mm.

AREA: 4.8 m²

TIPOLOGÍA: PC 2.6 - OX

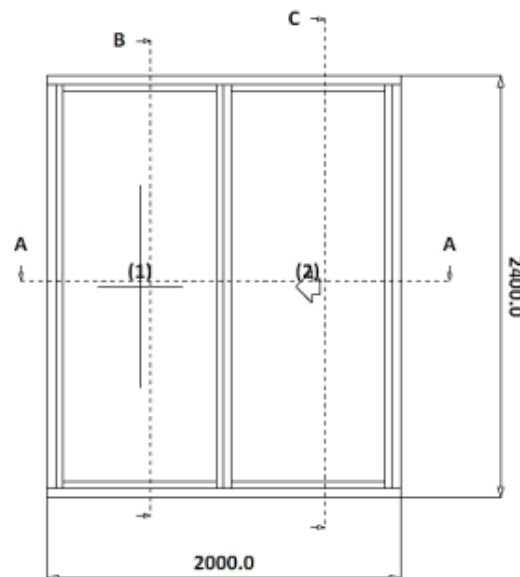

DESCRIPCIÓN DE LAS PRUEBAS	CLASE	ESTANDAR EUROPEO
PERMEABILIDAD AL AIRE	3	UNI EN 1026 - UNI EN 12207
ESTANQUEIDAD	A1	UNI EN 1027 - UNI EN 12208
RESISTENCIA A LA CARGA DEL VIENTO	W1B	UNI EN 12211 - UNI EN 12210

PRUEBA DE PERMEABILIDAD DEL AIRE

RESULTADO	ESCALA	DESCRIPCIÓN
CLASE 3	0 - 4	PÉRDIDA DE AIRE ENTRE ± 50 Y ± 600 Pa. VIENTOS ENTRE ≈33 Y ≈113 km/h.

PRUEBA DE ESTANQUEIDAD

RESULTADO	DESCRIPCIÓN
A1	INGRESO DE AGUA A PARTIR DE 50 Pa.

PRUEBA DE RESISTENCIA A LA CARGA DEL VIENTO

RESULTADO	DESCRIPCIÓN
W1	VALOR NOMINAL DE PRESIÓN 400 Pa. (HASTA 600 Pa.)
B	DEFORMACIÓN CALCULADA ES MAYOR QUE 1/200 Y MENOR QUE 1/150

Pa.: Pascal equivale a la presión que ejerce la fuerza de 1 Newton sobre una superficie de 1 m².
N.: Newton es la cantidad de fuerza aplicada durante 1 segundo a una masa de 1 kg., para que esta adquiriera la velocidad de 1 metro por segundo.

RESULTADO: TEST AEV 21-005

JUNIO 15: 2020 – FAPIM, ITALIA

MEDIDAS: (axh) 2.000 x 2.400 mm.

AREA: 4.8 m²

TIPOLOGÍA: PC 2.6 - OXXO

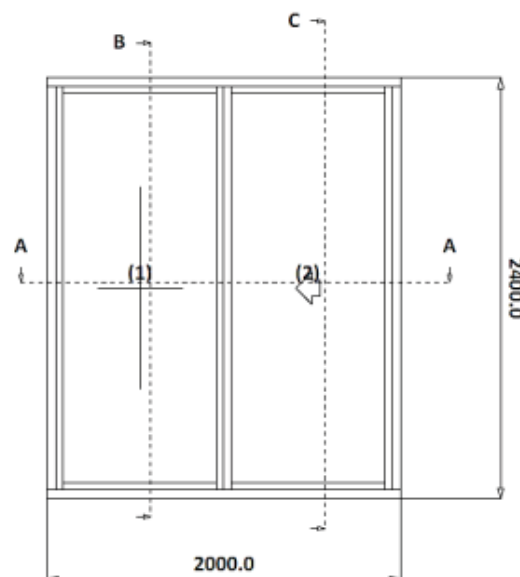

DESCRIPCIÓN DE LAS PRUEBAS	CLASE	ESTANDAR EUROPEO
PERMEABILIDAD AL AIRE	2	UNI EN 1026 - UNI EN 12207
ESTANQUEIDAD	A1	UNI EN 1027 - UNI EN 12208
RESISTENCIA A LA CARGA DEL VIENTO	W1B	UNI EN 12211 - UNI EN 12210

PRUEBA DE PERMEABILIDAD DEL AIRE

RESULTADO	ESCALA	DESCRIPCIÓN
CLASE 2	0 - 4	PÉRDIDA DE AIRE ENTRE ± 50 Y ± 600 Pa. VIENTOS ENTRE ≈ 33 Y ≈ 113 km/h.

PRUEBA DE ESTANQUEIDAD

RESULTADO	DESCRIPCIÓN
A1	INGRESO DE AGUA A PARTIR DE 50 Pa.

PRUEBA DE RESISTENCIA A LA CARGA DEL VIENTO

RESULTADO	DESCRIPCIÓN
W1	VALOR NOMINAL DE PRESIÓN 400 Pa. (HASTA 600 Pa.)
B	DEFORMACIÓN CALCULADA ES MAYOR QUE 1/200 Y MENOR QUE 1/150

Pa.: Pascal equivale a la presión que ejerce la fuerza de 1 Newton sobre una superficie de 1 m².
N.: Newton es la cantidad de fuerza aplicada durante 1 segundo a una masa de 1 kg., para que esta adquiera la velocidad de 1 metro por segundo.

TIPOLOGÍA XO ANJEO

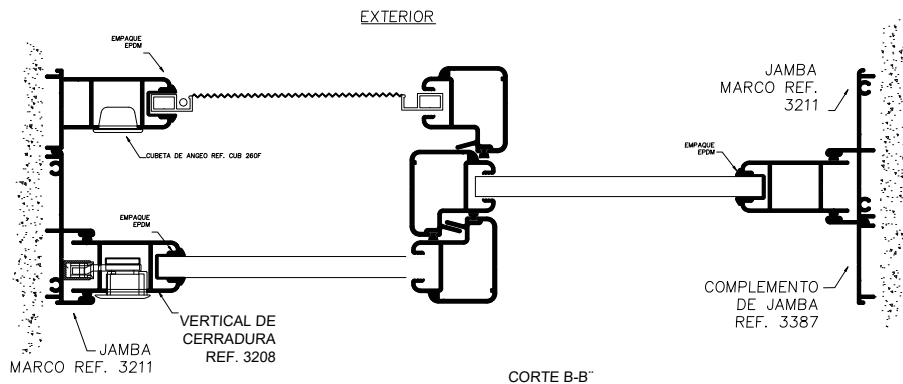
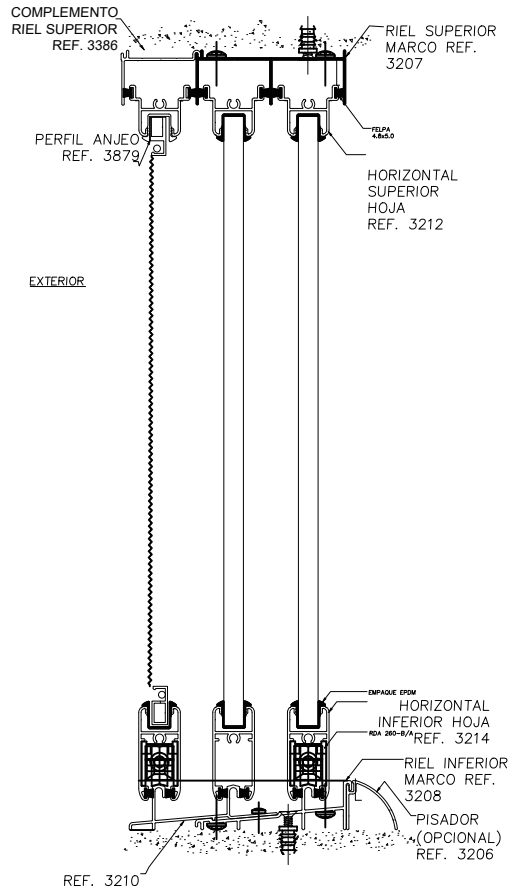
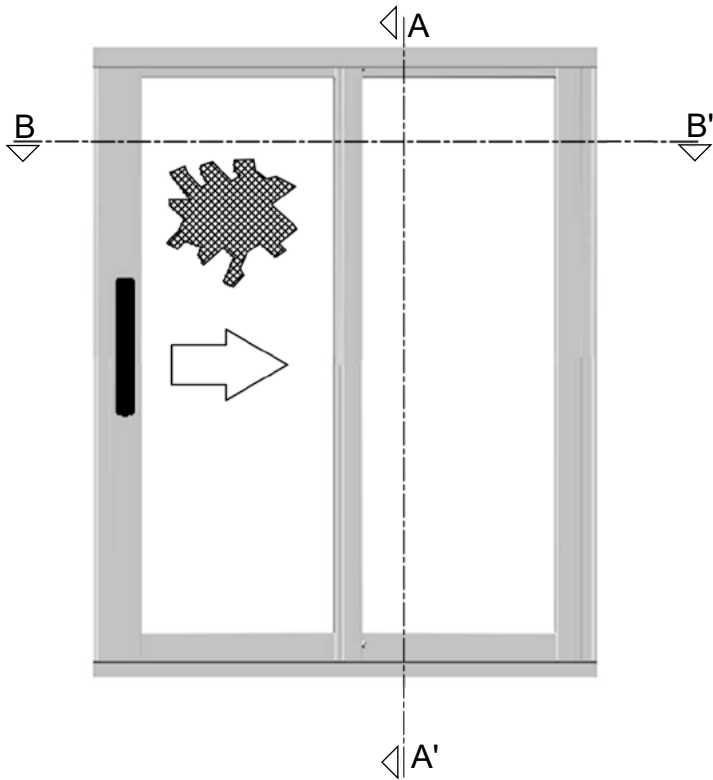

TIPOLOGÍAS

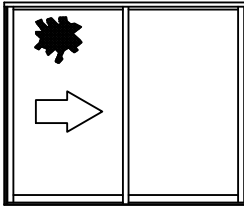

DISEÑO XO

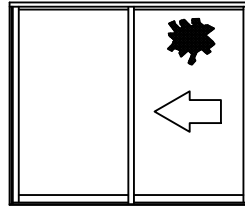

DISEÑO OX

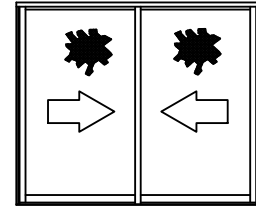

DISEÑO XX

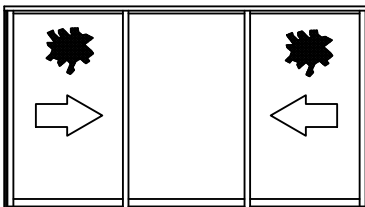

DISEÑO XOX $\frac{1}{3}$

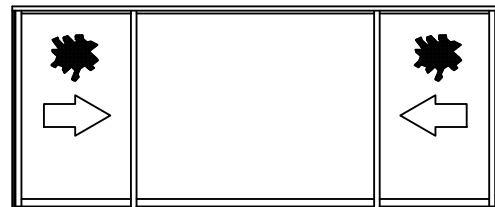

DISEÑO XOX $\frac{1}{4}$

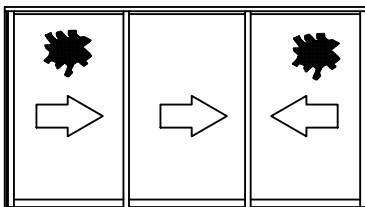

DISEÑO XXX

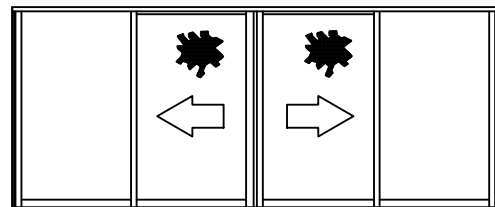

DISEÑO OXXO

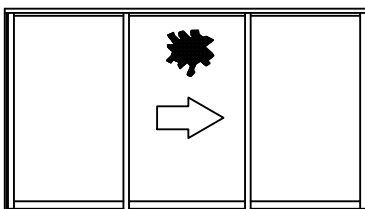

DISEÑO OXO-DER

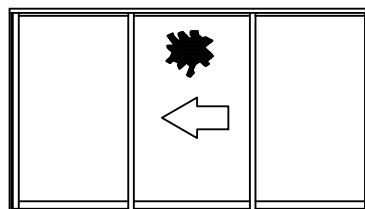

DISEÑO OXO-IZQ

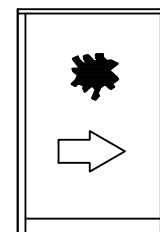

DISEÑO X

* Sistema Anjeo opcional.

REFERENCIAS BÁSICAS

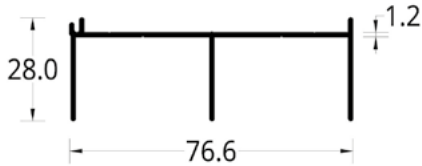

3207	CABEZAL COLOSAL 2.6 (76.6 X 28) mm
PESO 0,503 Kg/m	PERIMETRO 0,311 mm
UE 12	

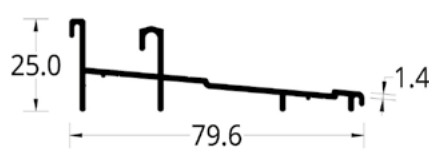

3208	SILLAR COLOSAL 2.6 (79.6 X 25) mm.
PESO 0,567 Kg/m	PERIMETRO 0,2965 mm
UE 12	

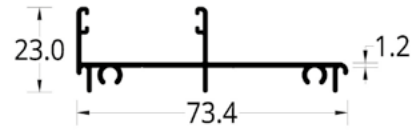

3211	JAMBA COLOSAL 2.6 (73.4 X 23) mm.
PESO 0,504 Kg/m	PERIMETRO 0,3063 mm
UE 12	

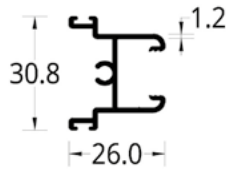

3212	HORIZONTAL SUPERIOR COLOSAL 2.6 (26 X 30.8) mm.
PESO 0,341 Kg/m	PERIMETRO 0,2121 mm
UE 24	

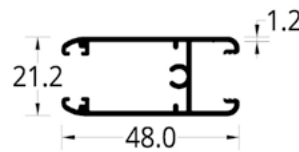

3214	HORIZONTAL INFERIOR MOVIL COLOSAL 2.6 (48 X 21.2) mm.
PESO 0,502 Kg/m	PERIMETRO 0,3039 mm
UE 12	

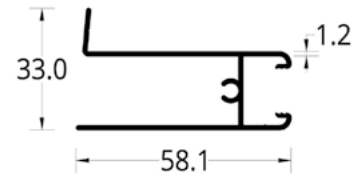

3213	HORIZONTAL INFERIOR FIJO COLOSAL 2.6 (58.1 X 33) mm.
PESO 0,531 Kg/m	PERIMETRO 0,329 mm
UE 12	

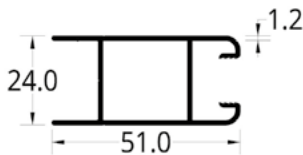

3215	TRASLAPE COLOSAL 2.6 (51 X 24) mm.
PESO 0,513 Kg/m	PERIMETRO 0,2324 mm
UE 12	

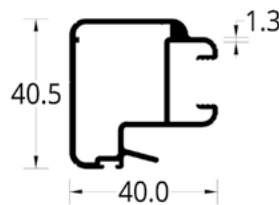

3216	ENGANCHE COLOSAL 2.6 (40 X 40.5) mm.
PESO 0,684 Kg/m	PERIMETRO 0,2385 mm
UE 12	

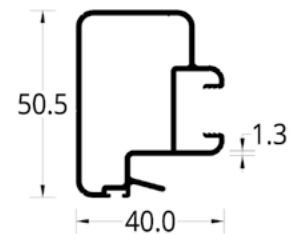

3385	ENGANCHE REFORZADO COLOSAL 2.6 (40 X 50.5) mm.
PESO 0,701 Kg/m	PERIMETRO 0,2585 mm
UE 12	

REFERENCIAS OPCIONALES



3386	COMPLEMENTO CABEZAL COLOSAL 2.6 (40.5 X 28) mm.	
PESO	PERIMETRO	UE
0,242 Kg/m	0,1494 mm	24

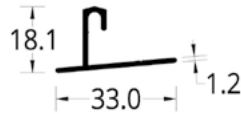

3209	GUIA SIMPLE COLOSAL 2.6 (33 X 25) mm.	
PESO	PERIMETRO	UE
0,198 Kg/m	0,1169 mm	24

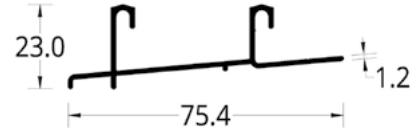

3210	GUIA DOBLE COLOSAL 2.6 (75.4 X 23) mm.	
PESO	PERIMETRO	UE
0,454 Kg/m	0,2664 mm	12



3387	COMPLEMENTO JAMBA COLOSAL 2.6 (40.6 X 8) mm.	
PESO	PERIMETRO	UE
0,188 Kg/m	0,1151 mm	24

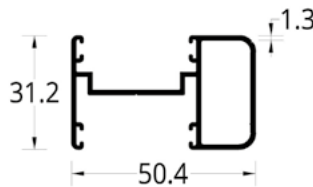

3524	ADAPTADOR COLOSAL 2.6 (50.4 X 31.2) mm.	
PESO	PERIMETRO	UE
0,592 Kg/m	0,2779 mm	10

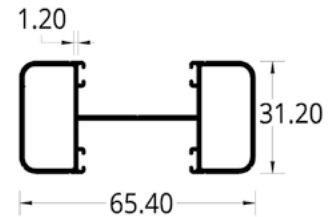

4967	ADAPTADOR REFORZADO COLOSAL 2.6 (65.4 X 31.2) mm.	
PESO	PERIMETRO	UE
0,784 Kg/m	0,288 mm	6

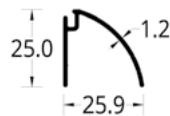

3206	PISADOR ASTRAL 1.7/2.0/ COLOSAL 2.6 (25.9 X 25) mm	
PESO	PERIMETRO	UE
0,213 Kg/m	0,1327 mm	24

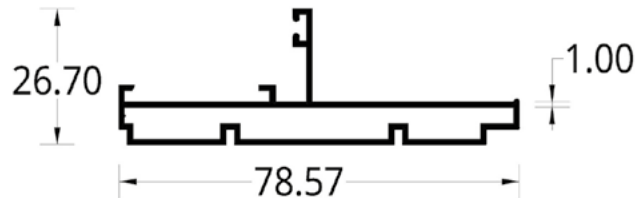

4919	PANORAMICO COLOSAL (78.57 X 26.7)	
PESO	PERIMETRO	UE
0,595 Kg/m	0,26 mm	8

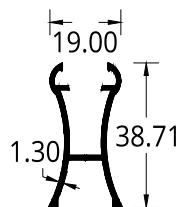

5016	REFUERZO UNIVERSAL COLOSAL 345 - 2.6 KIMBAYA -KALIMA (19.9 X 38.7)	
PESO	PERIMETRO	UE
0,345 Kg/m	0,199 mm	14



3712	TAPA REFUERZO KIMBAYA VERTICAL KIMBAYA/KALIMA (12.8 X 7.6) mm.	
PESO	PERIMETRO	UE
0,099 Kg/m	0,0449 mm	48

REFERENCIAS PC SATELITAL 2.6

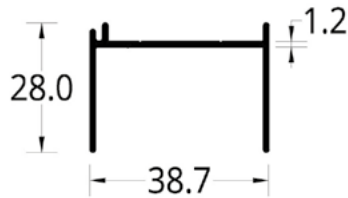

3382	CABEZAL SATELITAL 2.6 (38.7 X 28) mm.	
PESO	PERIMETRO	UE
0,307 Kg/m	0,189 mm	16

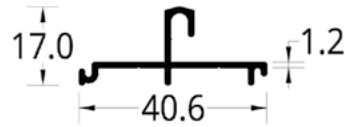

3383	CABEZAL SILLAR SATELITAL 2.6 (40.6 X 17) mm.	
PESO	PERIMETRO	UE
0,248 Kg/m	0,149 mm	24

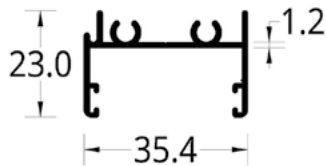

3384	JAMBA SATELITAL 2.6 (35.4 X 23) mm.	
PESO	PERIMETRO	UE
0,356 Kg/m	0,2195 mm	12

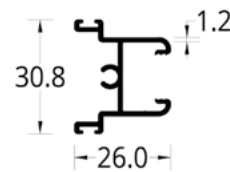

3212	HORIZONTAL SUPERIOR COLOSAL 2.6 (26 X 30.8) mm.	
PESO	PERIMETRO	UE
0,341 Kg/m	0,2121 mm	24

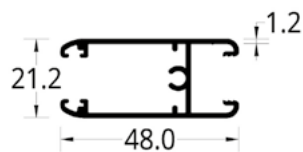

3214	HORIZONTAL INFERIOR MOVIL COLOSAL 2.6 (48 X 21.2) mm.	
PESO	PERIMETRO	UE
0,502 Kg/m	0,3039 mm	12



3215	TRASLAPE COLOSAL 2.6 (51 X 24) mm.	
PESO	PERIMETRO	UE
0,513 Kg/m	0,2324 mm	12

PRESIONES, RESISTENCIAS Y TAMAÑOS

Cumpliendo las especificaciones de las Normas Colombianas de Diseño y Construcción Sismo resistente NSR-10, con el decreto 0340 de febrero de 2012, específicamente el Capítulo B.6, como base de análisis realizamos el cálculo para las presiones de viento de las principales ciudades de Colombia como Bogotá (Región 2), Cali (Región 3), Medellín (Región 4) y Barranquilla (Región 5) según la figura B.6.4-1 en la

región eólica específica de cada ciudad, con exposición B, factor de importancia I y sin afectación topográfica; para el caso particular de indicar la metodología de análisis se considerara la ciudad de Bogotá como ejemplo a una altura máxima de instalación del sistema de ventanearía a 50 m sobre el nivel del andén. Este análisis se muestra en el siguiente cuadro:



TABLA DE RESTRICCIONES TR-01

INDICE

VERTICAL
Vertical perfil 2 3216

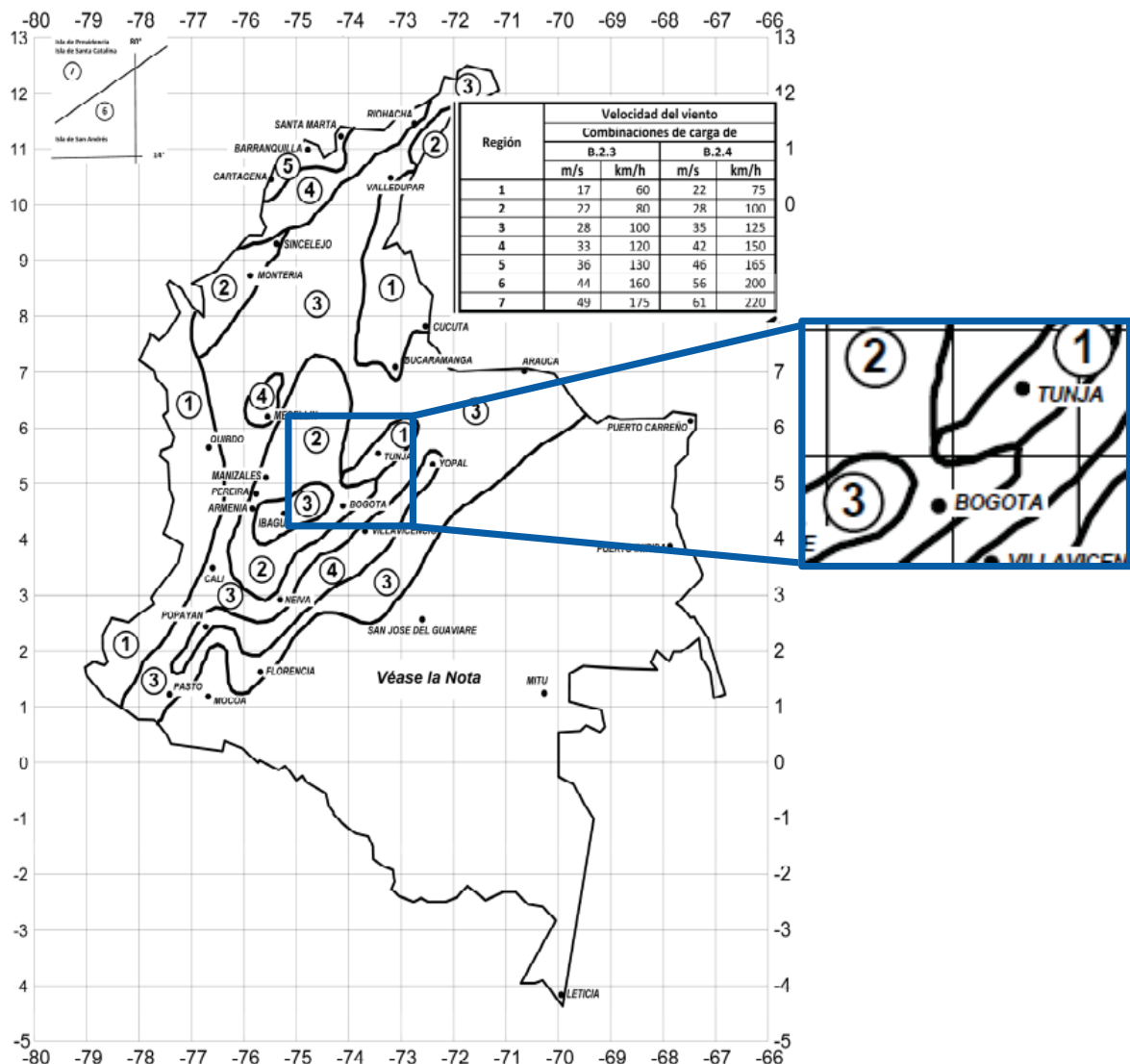
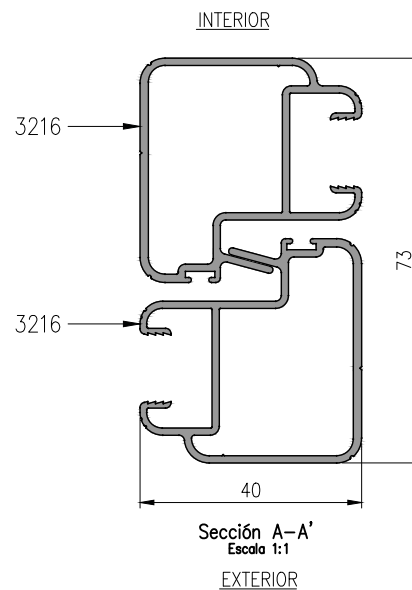
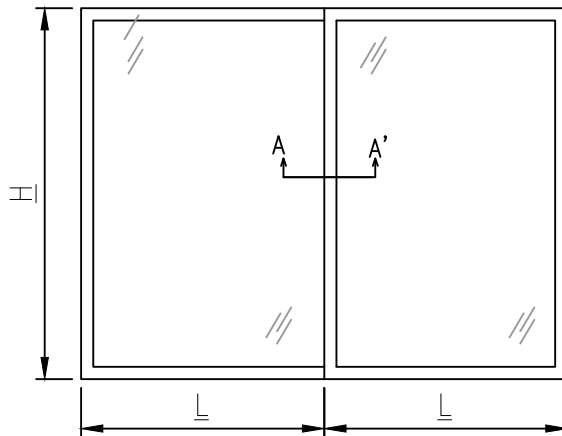

Altura de la puerta H [m]	2.30	0.42														
	2.20	0.48	0.42													
	2.10	0.56	0.48	0.43	0.39											
	2.00	0.65	0.56	0.50	0.45	0.42	0.39									
	1.90	0.76	0.66	0.59	0.53	0.49	0.46	0.43	0.41	0.39	0.38					
	1.80	0.90	0.78	0.70	0.63	0.58	0.54	0.52	0.49	0.47	0.46	0.45	0.45	0.45	0.45	0.45
	1.70	1.07	0.93	0.84	0.76	0.70	0.66	0.63	0.60	0.58	0.57	0.56	0.56	0.56	0.56	0.56
	1.60	1.29	1.13	1.01	0.93	0.86	0.81	0.77	0.75	0.73	0.72	0.71	0.71	0.71	0.71	0.71
	1.50	1.58	1.39	1.25	1.14	1.07	1.01	0.97	0.95	0.93	0.92	0.92	0.92	0.92	0.92	0.92
	1.40	1.96	1.73	1.56	1.44	1.35	1.29	1.25	1.23	1.22	1.22	1.22	1.22	1.22	1.22	1.22
	1.30	2.48	2.20	1.99	1.85	1.75	1.69	1.65	1.64	1.64	1.64	1.64	1.64	1.64	1.64	1.64
	1.20	3.20	2.85	2.61	2.45	2.34	2.28	2.25	2.25	2.25	2.25	2.25	2.25	2.25	2.25	2.25
	1.10	4.24	3.80	3.52	3.33	3.23	3.19	3.19	3.19	3.19	3.19	3.19	3.19	3.19	3.19	3.19
1.00	5.78	5.26	4.92	4.74	4.67	4.67	4.67	4.67	4.67	4.67	4.67	4.67	4.67	4.67	4.67	
OX, XO, OXO, XOX	0.60	0.70	0.80	0.90	1.00	1.10	1.20	1.30	1.40	1.50	1.60	1.70	1.80	1.90	2.00	
Ancho de nave L [m]																
PRESION RESISTENTE [kN/m²]																

PRESIONES DE VIENTO SEGÚN NSR10 - [kN/m ²]				
ALTURA DE INSTALACIÓN (M)	BOGOTÁ	CALI	MEDELLÍN	B/QUILLA
3	0.40	0.40	0.40	0.40
5	0.40	0.40	0.40	0.40
10	0.40	0.40	0.40	0.41
15	0.40	0.40	0.40	0.46
20	0.40	0.40	0.43	0.51
30	0.40	0.40	0.47	0.56
40	0.40	0.40	0.51	0.61
50	0.40	0.40	0.55	0.65
60	0.40	0.41	0.58	0.69
70	0.40	0.43	0.60	0.72
80	0.40	0.45	0.63	0.75
90	0.40	0.47	0.65	0.77
100	0.40	0.48	0.67	0.78

NOTAS:

- Se considera un factor de deflexión máxima horizontal de L/175
- Se considera uso de aluminio extruido aleación 6063 T5.
- Se deben evaluar las presiones particulares de cada proyecto y la zona de exposición de la ventana, centrales (zona 4) y esquina (zona 5), ver figura B.6.5-14 (NSR10).
- La presente tabla no aplica para vidrios DVH/ Cámara.

TABLA DE RESTRICCIONES TR-02

INDICE

VERTICAL
Enganche perfiles 3216 + 3385

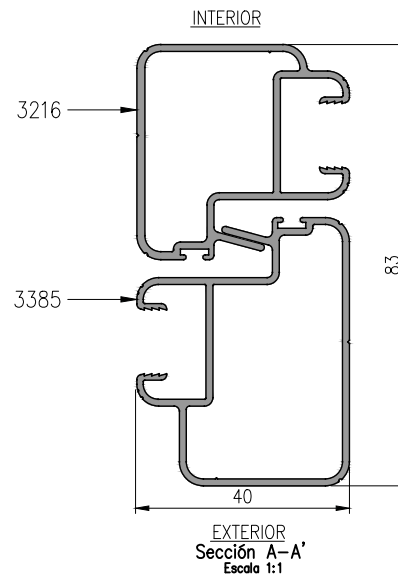
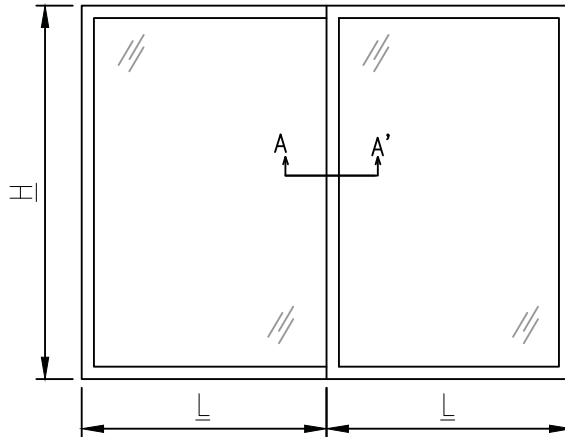

Altura de la puerta H [m]	2.50	0.43															
	2.40	0.48	0.42														
	2.30	0.55	0.48	0.42	0.38												
	2.20	0.63	0.55	0.49	0.44	0.40											
	2.10	0.73	0.63	0.56	0.51	0.47	0.43	0.40	0.38								
	2.00	0.85	0.74	0.65	0.59	0.54	0.50	0.47	0.45	0.43	0.42	0.40	0.39	0.39	0.38	0.38	
	1.90	0.99	0.86	0.77	0.70	0.64	0.60	0.56	0.54	0.51	0.50	0.49	0.48	0.47	0.47	0.47	
	1.80	1.17	1.02	0.91	0.83	0.76	0.71	0.68	0.64	0.62	0.60	0.59	0.59	0.58	0.58	0.58	
	1.70	1.40	1.22	1.09	1.00	0.92	0.86	0.82	0.79	0.76	0.75	0.74	0.73	0.73	0.73	0.73	
	1.60	1.69	1.48	1.33	1.21	1.12	1.06	1.01	0.98	0.95	0.94	0.93	0.93	0.93	0.93	0.93	
	1.50	2.06	1.81	1.63	1.49	1.40	1.33	1.27	1.24	1.22	1.21	1.21	1.21	1.21	1.21	1.21	
	1.40	2.56	2.26	2.04	1.88	1.77	1.69	1.64	1.60	1.59	1.59	1.59	1.59	1.59	1.59	1.59	
1.30	3.24	2.87	2.61	2.43	2.29	2.21	2.16	2.14	2.14	2.14	2.14	2.14	2.14	2.14	2.14		
OX, XO, OXO, XOX	0.60	0.70	0.80	0.90	1.00	1.10	1.20	1.30	1.40	1.50	1.60	1.70	1.80	1.90	2.00		
Ancho de nave L [m]																	
PRESION RESISTENTE [kN/m²]																	

PRESIONES DE VIENTO SEGÚN NSR10 - [kN/m ²]				
ALTURA DE INSTALACIÓN (M)	BOGOTÁ	CALI	MEDELLÍN	B/QUILLA
3	0.40	0.40	0.40	0.40
5	0.40	0.40	0.40	0.40
10	0.40	0.40	0.40	0.41
15	0.40	0.40	0.40	0.46
20	0.40	0.40	0.43	0.51
30	0.40	0.40	0.47	0.56
40	0.40	0.40	0.51	0.61
50	0.40	0.40	0.55	0.65
60	0.40	0.41	0.58	0.69
70	0.40	0.43	0.60	0.72
80	0.40	0.45	0.63	0.75
90	0.40	0.47	0.65	0.77
100	0.40	0.48	0.67	0.78

NOTAS:

- Se considera un factor de deflexión máxima horizontal de L/175
- Se considera uso de aluminio extruido aleación 6063 T5.
- Se deben evaluar las presiones particulares de cada proyecto y la zona de exposición de la ventana, centrales (zona 4) y esquina (zona 5), ver figura B.6.5-14 (NSR10).
- La presente tabla no aplica para vidrios DVH/ Cámara.

TABLA DE RESTRICCIONES TR-03

INDICE

VERTICAL
Enganche perfiles 2 3385

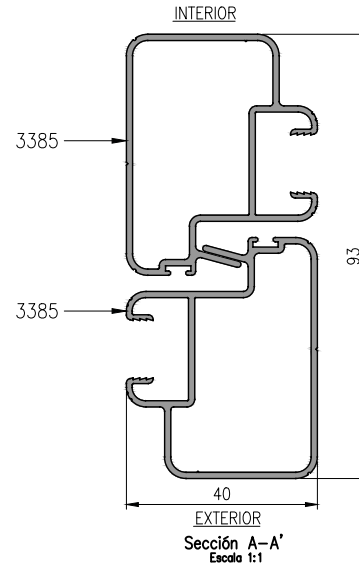
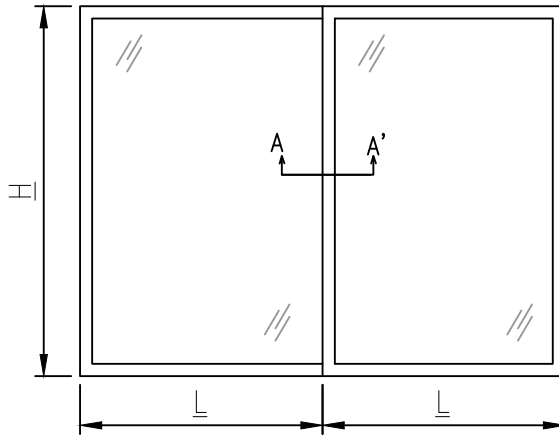

Altura de la puerta H [m]	2.70	0.42														
	2.60	0.47	0.41													
	2.50	0.53	0.46	0.40												
	2.40	0.60	0.52	0.46	0.41											
	2.30	0.68	0.59	0.52	0.47	0.43	0.40									
	2.20	0.78	0.68	0.60	0.54	0.50	0.46	0.43	0.40	0.38						
	2.10	0.90	0.78	0.69	0.63	0.57	0.53	0.50	0.47	0.45	0.43	0.42	0.41	0.40	0.39	0.39
	2.00	1.05	0.91	0.81	0.73	0.67	0.62	0.58	0.56	0.53	0.51	0.50	0.49	0.48	0.47	0.47
	1.90	1.23	1.07	0.95	0.86	0.79	0.74	0.69	0.66	0.64	0.61	0.60	0.59	0.58	0.58	0.58
	1.80	1.45	1.26	1.13	1.02	0.94	0.88	0.83	0.80	0.77	0.75	0.73	0.72	0.72	0.72	0.72
	1.70	1.73	1.51	1.35	1.23	1.14	1.07	1.01	0.97	0.94	0.92	0.91	0.90	0.90	0.90	0.90
	1.60	2.09	1.83	1.64	1.50	1.39	1.31	1.25	1.21	1.18	1.16	1.15	1.15	1.15	1.15	1.15
	1.50	2.55	2.24	2.02	1.85	1.73	1.64	1.57	1.53	1.50	1.49	1.49	1.49	1.49	1.49	1.49
1.40	3.17	2.79	2.52	2.33	2.19	2.08	2.02	1.98	1.97	1.97	1.97	1.97	1.97	1.97	1.97	
1.30	4.01	3.55	3.22	3.00	2.83	2.73	2.67	2.64	2.64	2.64	2.64	2.64	2.64	2.64	2.64	
OX, XO, OXO, XOX	0.60	0.70	0.80	0.90	1.00	1.10	1.20	1.30	1.40	1.50	1.60	1.70	1.80	1.90	2.00	
Ancho de nave L [m]																
PRESION RESISTENTE [kN/m²]																

ALTURA DE INSTALACIÓN (M)	BOGOTÁ	CALI	MEDELLÍN	B/QUILLA
3	0.40	0.40	0.40	0.40
5	0.40	0.40	0.40	0.40
10	0.40	0.40	0.40	0.41
15	0.40	0.40	0.40	0.46
20	0.40	0.40	0.43	0.51
30	0.40	0.40	0.47	0.56
40	0.40	0.40	0.51	0.61
50	0.40	0.40	0.55	0.65
60	0.40	0.41	0.58	0.69
70	0.40	0.43	0.60	0.72
80	0.40	0.45	0.63	0.75
90	0.40	0.47	0.65	0.77
100	0.40	0.48	0.67	0.78

NOTAS:

- Se considera un factor de deflexión máxima horizontal de L/175
- Se considera uso de aluminio extruido aleación 6063 T5.
- Se deben evaluar las presiones particulares de cada proyecto y la zona de exposición de la ventana, centrales (zona 4) y esquina (zona 5), ver figura B.6.5-14 (NSR10).
- La presente tabla no aplica para vidrios DVH/ Cámara.

TABLA DE RESTRICCIONES TR-04

INDICE

VERTICAL

Enganche perfiles 2 3215 + 3524

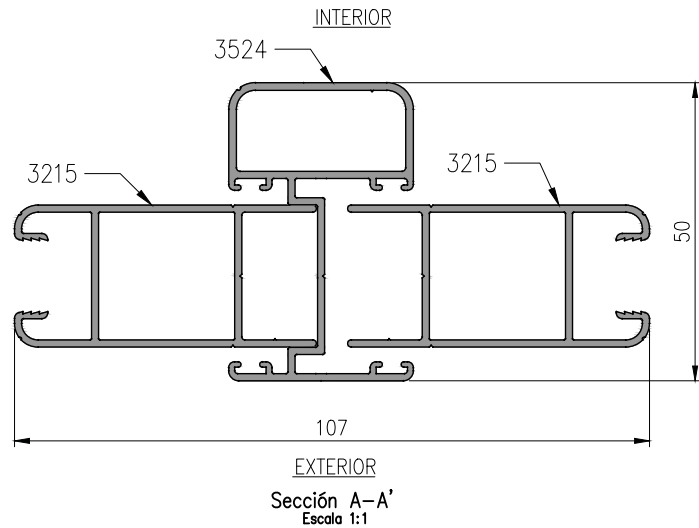
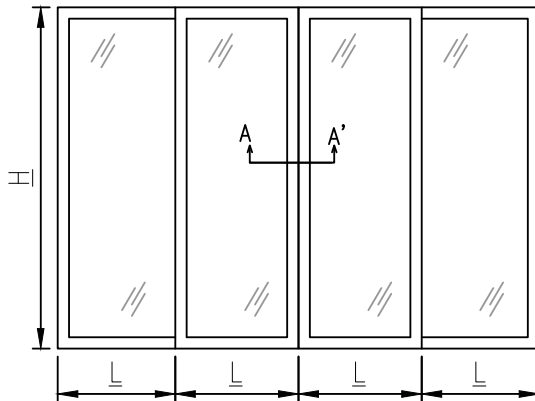

Altura de la puerta H [m]	2.50	0.40															
	2.40	0.46	0.40														
	2.30	0.52	0.45	0.40													
	2.20	0.60	0.52	0.46	0.41												
	2.10	0.69	0.60	0.53	0.48	0.44	0.41	0.38									
	2.00	0.80	0.69	0.62	0.56	0.51	0.48	0.45	0.42	0.41	0.39						
	1.90	0.94	0.81	0.72	0.66	0.60	0.56	0.53	0.50	0.48	0.47	0.46	0.45	0.44	0.44	0.44	0.44
	1.80	1.10	0.96	0.86	0.78	0.72	0.67	0.64	0.61	0.58	0.57	0.56	0.55	0.55	0.55	0.55	0.55
	1.70	1.32	1.15	1.03	0.94	0.87	0.81	0.77	0.74	0.72	0.70	0.69	0.69	0.69	0.69	0.69	0.69
	1.60	1.59	1.39	1.25	1.14	1.06	1.00	0.95	0.92	0.90	0.88	0.88	0.88	0.88	0.88	0.88	0.88
	1.50	1.94	1.71	1.54	1.41	1.32	1.25	1.20	1.17	1.15	1.14	1.14	1.14	1.14	1.14	1.14	1.14
	1.40	2.42	2.13	1.92	1.78	1.67	1.59	1.54	1.51	1.50	1.50	1.50	1.50	1.50	1.50	1.50	1.50
1.30	3.06	2.71	2.45	2.28	2.16	2.08	2.04	2.02	2.02	2.02	2.02	2.02	2.02	2.02	2.02	2.02	
OXO, OXXO	0.60	0.70	0.80	0.90	1.00	1.10	1.20	1.30	1.40	1.50	1.60	1.70	1.80	1.90	2.00	2.00	
Ancho de nave L [m]																	
PRESION RESISTENTE [kN/m²]																	

ALTURA DE INSTALACIÓN (M)	BOGOTÁ	CALI	MEDELLÍN	B/QUILLA
3	0.40	0.40	0.40	0.40
5	0.40	0.40	0.40	0.40
10	0.40	0.40	0.40	0.41
15	0.40	0.40	0.40	0.46
20	0.40	0.40	0.43	0.51
30	0.40	0.40	0.47	0.56
40	0.40	0.40	0.51	0.61
50	0.40	0.40	0.55	0.65
60	0.40	0.41	0.58	0.69
70	0.40	0.43	0.60	0.72
80	0.40	0.45	0.63	0.75
90	0.40	0.47	0.65	0.77
100	0.40	0.48	0.67	0.78

NOTAS:

- Se considera un factor de deflexión máxima horizontal de L/175
- Se considera uso de aluminio extruido aleación 6063 T5.
- Se deben evaluar las presiones particulares de cada proyecto y la zona de exposición de la ventana, centrales (zona 4) y esquina (zona 5), ver figura B.6.5-14 (NSR10).
- La presente tabla no aplica para vidrios DVH/ Cámara.

TABLA DE RESTRICCIONES TR-05

INDICE

VERTICAL

Enganche perfiles 2 3215 + 4967

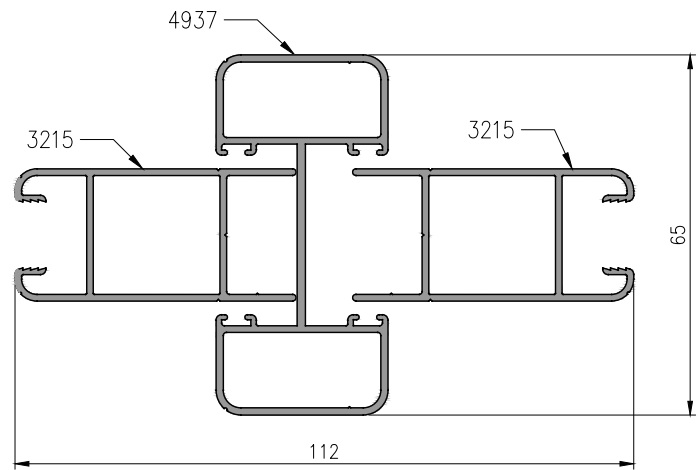
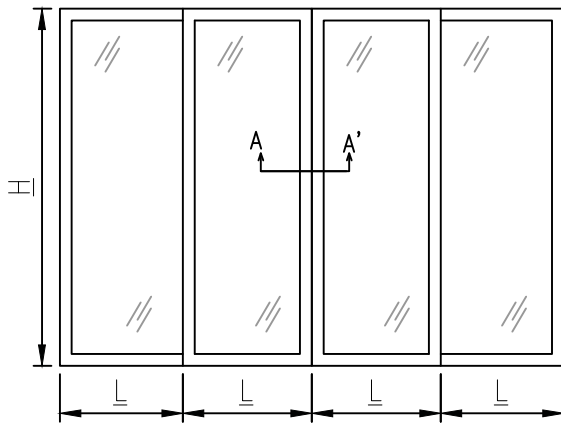

EXTERIOR
Sección A-A'
Escala 1:1

Altura de la ventana H [m]	2.70	0.55	0.47	0.42												
	2.60	0.61	0.53	0.47	0.42	0.38										
	2.50	0.69	0.60	0.53	0.47	0.43	0.40									
	2.40	0.78	0.68	0.60	0.54	0.49	0.45	0.42	0.40							
	2.30	0.89	0.77	0.68	0.61	0.56	0.52	0.48	0.46	0.43	0.41	0.40	0.39			
	2.20	1.02	0.88	0.78	0.71	0.65	0.60	0.56	0.53	0.50	0.48	0.46	0.45	0.44	0.43	0.43
	2.10	1.18	1.02	0.90	0.82	0.75	0.70	0.65	0.62	0.59	0.57	0.55	0.53	0.52	0.51	0.51
	2.00	1.37	1.19	1.05	0.95	0.88	0.81	0.76	0.73	0.69	0.67	0.65	0.64	0.63	0.62	0.62
	1.90	1.60	1.39	1.24	1.12	1.03	0.96	0.91	0.86	0.83	0.80	0.78	0.77	0.76	0.76	0.76
	1.80	1.89	1.65	1.47	1.34	1.23	1.15	1.09	1.04	1.00	0.97	0.96	0.95	0.94	0.94	0.94
	1.70	2.26	1.97	1.76	1.61	1.48	1.39	1.32	1.27	1.23	1.20	1.19	1.18	1.18	1.18	1.18
1.60	2.72	2.38	2.14	1.95	1.81	1.71	1.63	1.57	1.54	1.52	1.50	1.50	1.50	1.50	1.50	
OXO, OXOXO	0.60	0.70	0.80	0.90	1.00	1.10	1.20	1.30	1.40	1.50	1.60	1.70	1.80	1.90	2.00	
Ancho de nave L [m]																
PRESION RESISTENTE [kN/m²]																

PRESIONES DE VIENTO SEGÚN NSR10 - [kN/m ²]				
ALTURA DE INSTALACIÓN (M)	BOGOTÁ	CALI	MEDELLÍN	B/QUILLA
3	0.40	0.40	0.40	0.40
5	0.40	0.40	0.40	0.40
10	0.40	0.40	0.40	0.41
15	0.40	0.40	0.40	0.46
20	0.40	0.40	0.43	0.51
30	0.40	0.40	0.47	0.56
40	0.40	0.40	0.51	0.61
50	0.40	0.40	0.55	0.65
60	0.40	0.41	0.58	0.69
70	0.40	0.43	0.60	0.72
80	0.40	0.45	0.63	0.75
90	0.40	0.47	0.65	0.77
100	0.40	0.48	0.67	0.78

NOTAS:

- Se considera un factor de deflexión máxima horizontal de L/175
- Se considera uso de aluminio extruido aleación 6063 T5.
- Se deben evaluar las presiones particulares de cada proyecto y la zona de exposición de la ventana, centrales (zona 4) y esquina (zona 5), ver figura B.6.5-14 (NSR10).
- La presente tabla no aplica para vidrios DVH/ Cámara.

TABLA DE DESCUENTOS OX - XO

Ancho	(A)	O	Fijo
Alto	(H)	X	Móvil

Marco				
Referencia	Descripción	Cantidad	Formula de corte	Cortes
3207	CABEZAL COLOSAL 2.6 (76.6 X 28) mm.	1	A= Ancho	90° dos extremos
3208	SILLAR COLOSAL 2.6 (79.6 X 25) mm.	1	A= Ancho	90° dos extremos
3211	JAMBA COLOSAL 2.6 (73.4 X 23) mm.	2	H-11 mm	5° extremo inferior y 90° extremo superior
Naves				
Referencia	Descripción	Cantidad	Formula de corte	Cortes
3212	HORIZONTAL SUPERIOR COLOSAL 2.6 (26 X 30.8) mm.	2	(A/2) -8 mm	90° dos extremos
3213	HORIZONTAL INFERIOR FIJO COLOSAL 2.6 (58.1 X 33) mm.	1	(A/2) -8 mm	90° dos extremos
3214	HORIZONTAL INFERIOR MOVIL COLOSAL 2.6 (48 X 21.2) mm.	1	(A/2) -8 mm	90° dos extremos
3215	TRASLAPE COLOSAL 2.6 (51 X 24) mm.	1	H -23 mm	5° extremo inferior 90° superior
3215	TRASLAPE COLOSAL 2.6 (51 X 24) mm.	1	H -33 mm	90° dos extremos
3216	ENGANCHE COLOSAL 2.6 (40 X 40.5) mm.	1	H -23 mm	5° extremo inferior 90° superior
3216	ENGANCHE COLOSAL 2.6 (40 X 40.5) mm.	1	H -33 mm	90° dos extremos
3385	ENGANCHE REFORZADO COLOSAL 2.6 (40 X 50.5) mm.	2	H -23 mm	5° extremo inferior 90° superior
3385	ENGANCHE REFORZADO COLOSAL 2.6 (40 X 50.5) mm.	2	H -33 mm	90° dos extremos

XX

Marco				
Referencia	Descripción	Cantidad	Formula de corte	Cortes
3207	CABEZAL COLOSAL 2.6 (76.6 X 28) mm.	1	A= Ancho	90° dos extremos
3208	SILLAR COLOSAL 2.6 (79.6 X 25) mm.	1	A= Ancho	90° dos extremos
3209	GUIA SIMPLE COLOSAL 2.6 (33 X 25) mm.	1	A - 16 mm	90° dos extremos
3211	JAMBA COLOSAL 2.6 (73.4 X 23) mm.	2	H-11 mm	5° extremo inferior y 90° extremo superior
Naves				
Referencia	Descripción	Cantidad	Formula de corte	Cortes
3212	HORIZONTAL SUPERIOR COLOSAL 2.6 (26 X 30.8) mm.	2	(A/2) -8 mm	90° dos extremos
3214	HORIZONTAL INFERIOR MOVIL COLOSAL 2.6 (48 X 21.2) mm.	2	(A/2) -8 mm	90° dos extremos
3215	TRASLAPE COLOSAL 2.6 (51 X 24) mm.	2	H -33 mm	5° extremo inferior 90° superior
3216	ENGANCHE COLOSAL 2.6 (40 X 40.5) mm.	2	H -33 mm	90° dos extremos
3385	ENGANCHE REFORZADO COLOSAL 2.6 (40 X 50.5) mm.	2	H -33 mm	90° dos extremos

XXX

Marco				
Referencia	Descripción	Cantidad	Formula de corte	Cortes
3207	CABEZAL COLOSAL 2.6 (76.6 X 28) mm.	1	A= Ancho	90° dos extremos
3208	SILLAR COLOSAL 2.6 (79.6 X 25) mm.	1	A= Ancho	90° dos extremos
3210	GUIA DOBLE COLOSAL 2.6 (75.4 X 23) mm.	1	A - 16 mm	90° dos extremos
3211	JAMBA COLOSAL 2.6 (73.4 X 23) mm.	2	H-11 mm	5° extremo inferior y 90° extremo superior
3386	COMPLEMENTO CABEZAL COLOSAL 2.6 (40.5 X 28) mm.	1	A= Ancho	90° dos extremos
3387	COMPLEMENTO JAMBA COLOSAL 2.6 (40.6 X 8) mm.	2	H-11 mm	5° extremo inferior y 90° extremo superior
Naves				
Referencia	Descripción	Cantidad	Formula de corte	Cortes
3212	HORIZONTAL SUPERIOR COLOSAL 2.6 (26 X 30.8) mm.	3	(A/3) +7 mm	90° dos extremos
3214	HORIZONTAL INFERIOR MOVIL COLOSAL 2.6 (48 X 21.2) mm.	3	(A/3) +7 mm	90° dos extremos
3215	TRASLAPE COLOSAL 2.6 (51 X 24) mm.	2	H -33 mm	5° extremo inferior 90° superior
3216	ENGANCHE COLOSAL 2.6 (40 X 40.5) mm.	4	H -33 mm	90° dos extremos

OXO

Ancho	(A)	O	Fijo
Alto	(H)	X	Móvil

Marco				
Referencia	Descripción	Cantidad	Formula de corte	Cortes
3207	CABEZAL COLOSAL 2.6 (76.6 X 28) mm.	1	A= Ancho	90° dos extremos
3208	SILLAR COLOSAL 2.6 (79.6 X 25) mm.	1	A= Ancho	90° dos extremos
3211	JAMBA COLOSAL 2.6 (73.4 X 23) mm.	2	H-11 mm	5° extremo inferior y 90° extremo superior
Naves				
Referencia	Descripción	Cantidad	Formula de corte	Cortes
3212	HORIZONTAL SUPERIOR COLOSAL 2.6 (26 X 30.8) mm.	4	(A/4) -3 mm	90° dos extremos
3213	HORIZONTAL INFERIOR FIJO COLOSAL 2.6 (58.1 X 33) mm.	2	(A/4) -3 mm	90° dos extremos
3214	HORIZONTAL INFERIOR MOVIL COLOSAL 2.6 (48 X 21.2) mm.	2	(A/4) -3 mm	90° dos extremos
3215	TRASLAPE COLOSAL 2.6 (51 X 24) mm.	2	H -23 mm	5° extremo inferior 90° superior
3215	TRASLAPE COLOSAL 2.6 (51 X 24) mm.	2	H -33 mm	90° dos extremos
3216	ENGANCHE COLOSAL 2.6 (40 X 40.5) mm.	2	H -23 mm	5° extremo inferior 90° superior
3216	ENGANCHE COLOSAL 2.6 (40 X 40.5) mm.	2	H -33 mm	90° dos extremos
3385	ENGANCHE REFORZADO COLOSAL 2.6 (40 X 50.5) mm.	2	H -23 mm	5° extremo inferior 90° superior
3385	ENGANCHE REFORZADO COLOSAL 2.6 (40 X 50.5) mm.	2	H -33 mm	90° dos extremos
3524	ADAPTADOR COLOSAL 2.6 (50.4 X 31.2) mm.	1	H -33 mm	90° dos extremos
4967	ADAPTADOR REFORZADO COLOSAL 2.6 (65.4 X 31.2) mm.	1	H -33 mm	90° dos extremos

TABLA DE DESCUENTOS SATELITAL

Marco				
Referencia	Descripción	Cantidad	Formula de corte	Cortes
3382	CABEZAL SATELITAL 2.6 (38.7 X 28) mm.	1	A= Ancho	90° dos extremos
3383	SILLAR SATELITAL 2.6 (40.6 X 17) mm.	1	A= Ancho	90° dos extremos
3384	JAMBA SATELITAL 2.6 (35.4 X 23) mm.	1	A= Ancho	90° dos extremos
Naves				
Referencia	Descripción	Cantidad	Formula de corte	Cortes
3212	HORIZONTAL SUPERIOR COLOSAL 2.6 (26 X 30.8) mm.	1	(A/2) -15 mm	90° dos extremos
3214	HORIZONTAL INFERIOR MOVIL COLOSAL 2.6 (48 X 21.2) mm.	1	(A/2) -15 mm	90° dos extremos
3215	TRASLAPE COLOSAL 2.6 (51 X 24) mm.	2	H -33 mm	90° dos extremos

CICLOS DE OPERACIÓN DE RODAMIENTOS

<p>Durability Test</p>	1RR 	CL. 3 10.000 cycles	CL. 4 15.000 cycles	CL. 5 25.000 cycles
		Kg 90	Kg 80	Kg 70
		Kg 90	Kg 80	Kg 70
		Kg 75	Kg 65	Kg 60
		Kg 50	Kg 45	Kg 35
	2RR 	Kg 180	Kg 160	Kg 140
		Kg 180	Kg 160	Kg 140
		Kg 130	Kg 120	Kg 100
		100	Kg 90	Kg 70

fapim

ACCESORIOS

INDICE



KIT DE CIERRE COLOSAL 2.6		
GRIS	CER 260F-0	UE 25
BLANCO	CER 260F-2	
NEGRO	CER 260F-3	



KIT DE CIERRE CON LLAVE COLOSAL 2.6		
GRIS	CER 260F-0K	UE 25
BLANCO	CER 260F-2K	
NEGRO	CER 260F-3K	



CUBETA DE ANGO NEGRA LINEA UNIVERSAL/LINEA EUROVITRAL	
CUB 260F-3	UE 50



RODAMIENTO SIMPLE EN AGUJAS 70 KILOS COLOSAL 2.6/COLOSAL 345		
RDA 260F-1	AGUJAS	UE 50
CARGA Rueda 35Kg. par 70Kg.		



RODAMIENTO DOBLE EN AGUJAS 140 KILOS COLOSAL 2.6/COLOSAL 345		
RDA 260F-2	AGUJAS	UE 50
CARGA Rueda 70Kg. par 140Kg.		



CAJA DEFLECTORA LINEA UNIVERSAL/EUROVITRAL	
CAD 320	UE 100

*Aplica para tipologías: XX - OXX - XXX
y Referencias: 3209 - 3210

EMPAQUES



EMPAQUE U PARA VIDRIO 6 MM COLOSAL 2.6/COLOSAL 345/SIDERAL	
EMV 260.6	



EMPAQUE U PARA VIDRIO 8 MM COLOSAL 2.6/COLOSAL 345/SIDERAL	
EMV 260.8	



EMPAQUE U PARA VIDRIO 10 MM COLOSAL 2.6/COLOSAL 345/SIDERAL	
EMV 260.10	

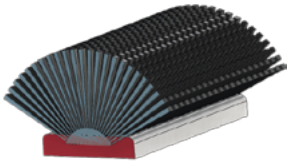

FELPA BASE 5.00 X ALTURA 5.00 MM
FEL 005

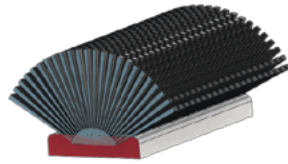

FELPA BASE 5.00 X ALTURA 7.00 MM
FEL 007

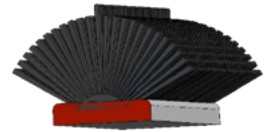

FELPA BASE 5.00 X ALTURA 7.00 MM
CON PLASTIFILM CENTRAL
FEL 007P

APLICACIÓN DE EMPAQUES

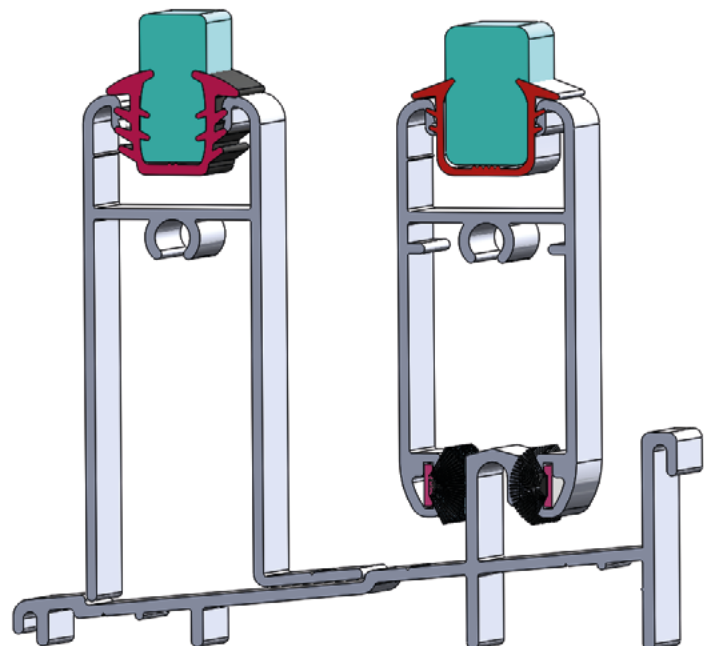
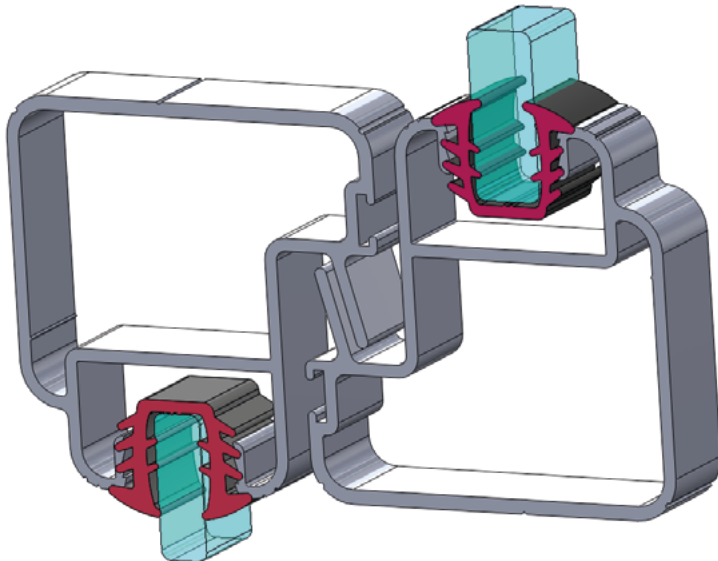

MAQUINARIA Y EQUIPO

PRENSA MANUAL DE
CREMALLERA SIN PEDESTAL
PREN 02S



PEDESTAL DE ANCLAJE
PARA PRENSA CREMALLERA
PED 03A

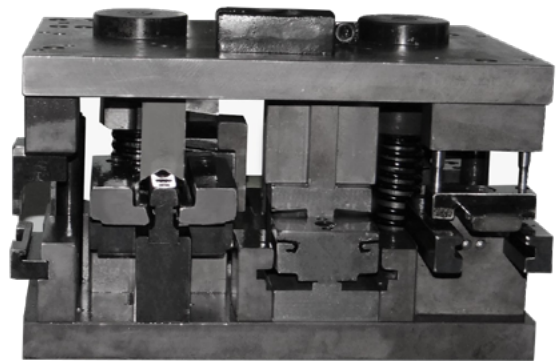

PUNZÓN 8 ESTACIONES COLOSAL 2.6
PUN COL8



 vitral.com.co/catalogos

 vitralcol4860  @vitral.sas  Vitral SAS

 **Vitral Bogotá**
Cra 52 No. 79-20
Tel: (57) 601 311 6400
 Cel: (57) 317 401 8367
317 401 8322
310 230 7356
317 401 8340
Línea Universal y EuroVital
318 629 7374

 **Vitral Cali**
Cll 25 No. 5-44
Tel: (57) 602 882 2694
 Cel: (57) 317 432 6909
313 765 5651
Línea Universal y EuroVital
317 511 4838